



INSTALLATION INSTRUCTIONS FOR UNIVERSAL DUCT SMOKE DETECTORS

MODEL 2650-660 Ionization
MODEL 2650-661 Photoelectric

PRODUCT OVERVIEW

PRODUCT APPLICATION:

The Firex Series Duct Smoke Detectors provide early detection of smoke and products of combustion present in the air moving through an HVAC duct in commercial, industrial and residential applications.

These devices are designed to prevent the recirculation of smoke in areas by the air handling systems, fans and blowers. Complete systems may be shut down in the event of smoke detection.

NOTE

For the correct installation of a duct smoke unit, please refer to the NFPA 72E (Standard for Automatic Fire Detectors) and NFPA 90A (Standard for Installation of Air Condition and Ventilation Systems.)

This detector is not intended for open area protection nor should it be used for early warning detection or replace a regular fire detection system.

Maple Chase provides a special U.L. 50 listed, NEMA 3R rated weatherproof enclosure separately (Model 0590) which should be used in appropriate outdoor applications for protection from the elements. Other installations above the roof line (attics, banjo type roofs, etc.) do not require the special Model 0590 weatherproof enclosure as long as the Maple Chase duct smoke detectors are not exposed to dripping water or other environmental elements. The Model 0590 weatherproof enclosure should be used in all applications where environmental elements are a concern or local code requires a weatherproof enclosure for proper installation. All installations of our duct smoke detectors and weatherproof enclosures should be done in accordance with all applicable electrical and building codes.

PRODUCT DESCRIPTION:

The Firex Smoke Detector is fitted with a mounting base that will accept an Ionization Detector Head Model # 2850 - 250 or Photoelectric Detector Head Model # 2850 - 350. The duct unit supports 2 sets of Form "C" Alarm Contacts and 1 form "C" Trouble Contact. The trouble contact supervises the presence of the input power and removal of the detector head.

THE TROUBLE CONTACTS (TERMINALS 13-14-15) ARE SHOWN IN THE NON-ENERGIZED CONDITION.

The trouble contact **will not** operate in the event of a smoke alarm.

The Firex Duct Detector models 2650-660 and 2650-661 will operate on one of the following input voltage sources: 24VAC, 24VDC, 115VAC and 230VAC.

The duct smoke detector units are designed to operate in duct widths from 12 inches to 10 feet wide with an air velocity between 500 and 4000 feet per minute. To verify correct installation, the pressure differential between the input and exhaust tubes should be measured using a Magnehelic pressure gauge or equivalent. An acceptable reading must be between 0.01 and 1.2 inches of water.

For a Smoke Duct Detector unit to operate correctly, it must be installed 6 duct widths from any obstruction i.e. elbows, deflector plates, filters, dampers, etc. In situations where the criteria cannot be met, deviations are acceptable providing they meet the pressure differential requirements.

SAMPLING TUBES:

The principal of operation of a duct detector is based on the Venturi effect. Two tubes extend into the HVAC duct. Air flowing through the duct is forced into the air intake tube via the air intake holes, and passes over the detector head. The air will be drawn out via the exhaust tube back into the HVAC duct. (7" exhaust tube provided in the installation kit.)

When the particles of smoke suspended in the air stream reach the alarm threshold of the detector head, the unit will go into alarm.

REMOTE ACCESSORIES:

Audible and visual alarm indicators, remote status indicators and remote reset/test switches can be accommodated by the Firex Duct units by connecting to the DC voltage output terminals 16 thru 21 (see page 6 for details). These terminals are not supervised and the current will only be present when the detector unit is in alarm. The remote pilot LED will be permanently illuminated when connected to the output terminals. Trouble contacts cannot be connected to a fire alarm panel when the trouble (yellow) LED is connected. When connecting the - trouble LED place a jumper between terminals 14 and 18.

Duct Unit Installation

DUCT SMOKE LOCATION PRE-REQUISITES:

This guideline contains general information on duct smoke detector installation, but does not preclude the NFPA documents listed. Maple Chase Company assumes no responsibility for improperly installed duct detectors. To determine the correct installation position for a Firex Duct Smoke Detector, the following factors must be considered.

- 1) A uniform non turbulent airflow of between 500 ft/min to 4000 ft/min. must be present in the HVAC duct. To determine the duct velocities examine the engineering specifications that define the expected velocities or use an Alnor model 6000P velocity/meter (or equivalent).
- 2) In order to prevent stratification, duct smoke units, where possible, must be located a minimum of six duct widths down stream from a source of turbulence i.e. elbows, deflector plates, filters, dampers, and inlets.

In installations where it is impossible to adhere to the six duct width requirement, units can be installed closer but as far from inlets, bends or deflector plates as possible. Should this situation arise, check velocity readings in the duct prior to the duct smoke unit installation. Ensure the duct smoke unit pressure differential complies with the unit specifications. The pressure differential between the input sampling tube and exhaust tube for the Firex series duct smoke unit should be greater than 0.01 inches of water and less than 1.2 inches of water.

- 3) Identify a location for the installation of the duct unit that will permit easy access for viewing and serviceability.
- 4) Install duct units in the return air side of an HVAC unit prior to the air being exhausted from the building or diluted with outside air.
- 5) When installing duct smoke units down stream of filters, fires occurring in the filters will be detected, but if the filters become blocked insufficient air flow through the duct unit will prevent the correct operation of the duct detector.
- 6) Where possible, install duct detectors upstream of air humidifiers and downstream of dehumidifiers.
- 7) To prevent false alarms, the duct detector should not be mounted in areas of extreme high or low temperatures, in areas where high humidity exists or in areas where the duct may contain gases or excess dust.

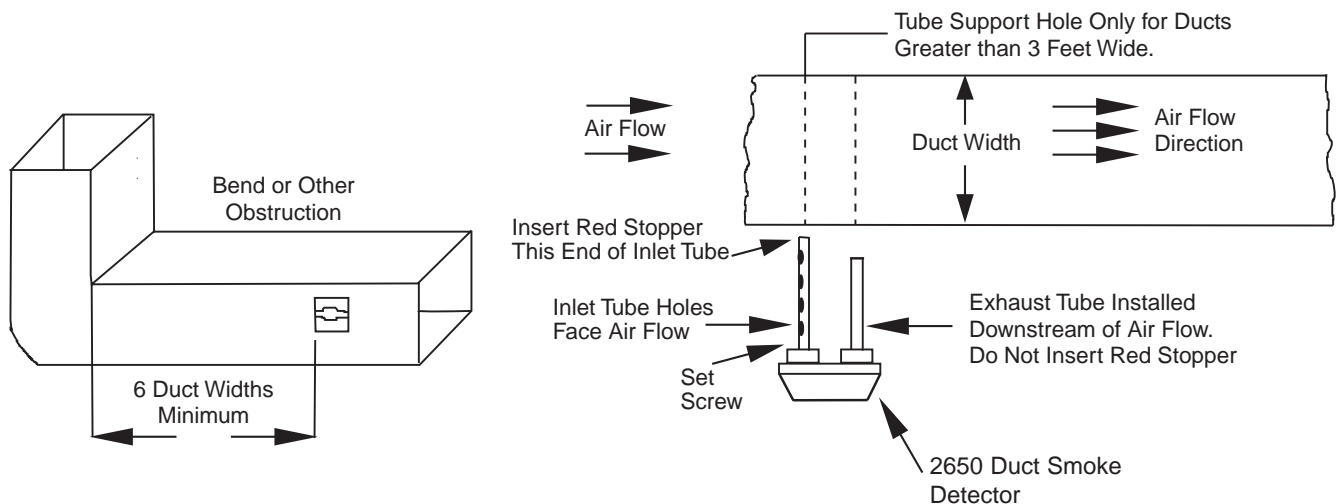

SAMPLING TUBE ASSEMBLY:

Sampling tubes are to be ordered separately in one of the 3 standard lengths.

532	For duct widths of	1.0' TO 2.5'
533	For duct widths of	2.5' TO 5.0'
534	For duct widths of	5.0' TO 10.0'

The standard sampling tubes are steel tubes with air intake holes drilled down the entire length of the tube. These tubes must be cut to length and must span the entire width of the duct. Sampling tubes over 3.0 feet must be supported on the opposite side of the duct. To ensure the correct operation of the sensing tube, the red end cap (red stopper in installation kit) must be inserted in the end of the air intake sampling tube.

Once the airflow direction has been determined, insert the inlet and exhaust tubes into the sampling tube connectors fitted to the back of the duct smoke detector which are equipped with set screws. These connectors will allow the tubes to be correctly orientated and secured by tightening the set screw. Ensure air intake sampling tube is positioned so that the inlet holes are facing the airflow.

DUCT PREPARATION:

For ease of duct unit installation, remove mounting template from the installation kit. Remove paper backing from the mounting template and affix it to the duct at the desired location. Using the template as a guide, drill 4 mounting holes (3/32" diam.) for the 12 X 1/2" sheet metal screws packaged in the installation kit.

Drill or punch 1 3/8" holes for sampling tubes, using the template as a guide. Clean all holes.

MOUNTING DUCT SMOKE DETECTOR:

After securing the sampling tubes to the duct smoke unit, or initially placing the tubes through the 1 3/8" holes drilled or punched in the HVAC duct to accept the sampling tubes and then attaching them to the duct unit. Hold the duct unit assembly in position and using 4# 12 X 1/2" sheet metal screws (Packaged in the installation kit) secure the duct smoke detector to the HVAC duct sheet metal work.

AIR SAMPLING VERIFICATION:

To ensure correct operation of the duct unit use a Magnehelic differential pressure gauge or Dwyer model 4000 to determine the differential pressure between the inlet and exhaust tubes. The differential pressure between the two tubes should be greater than 0.01 inches of water and less than 1.2 inches of water.

PRODUCT SPECIFICATIONS

Model Number:

2650 - 660 Ionization
24V AC/DC, 115V AC, 230V AC
2650 - 661 Photoelectric
24V AC/DC, 115V AC, 230V AC

Detector Model Number:

S60A Ionization Detector Head 2850 - 250
S60A Photoelectric Detector Head 2850 - 350

POWER REQUIREMENTS

QUIESCENT CURRENT

24V AC 35 mA
24V DC 15 mA

ALARM CURRENT

24V AC 74mA
24V DC 48mA

QUIESCENT CURRENT

115V AC 25mA

ALARM CURRENT

115V AC 32mA

QUIESCENT CURRENT

230V AC 12mA

ALARM CURRENT

230V AC 16mA

RELAY CONTACT RATINGS:

Alarm contacts: 2 form "C" rated at 12AMPS @ 125V AC resistive
Trouble contacts: 1 Set form "C" rated at 10AMPS @ 115V AC resistive
Air velocity: 500 to 4000 ft/min
Ambient temperature: Model 2650-660 32°F to 155°F (0°C to 68°C)
Model 2650-661 32°F to 100°F (0°C to 38°C)
Humidity: 10% to 85% R.H. no condensation
Material: 18GA Steel back box, clear plastic cover
Finish: Gray paint
Dimensions: L-9 1/8" X W-7 1/4" X H-2 1/4"
Max. net wt.: 3 1/2 lbs.
Radioactive element: For Firex 2650-660 (Ionization model)
Americium 241, 0.9 micro curie
Do not expose to corrosive atmospheres.

TEST PROCEDURES

OPERATIONAL TESTING

To determine the correct operation of the Firex Duct Smoke Detector, ensure power is connected and the green pilot LED is illuminated.

The LED on the detector head does not flash during the standby mode. The LED on the detector head will be permanently illuminated when smoke is detected and the head is in alarm.

With the air handling unit shut down, and the clear cover removed, press and hold the test/reset button on the Firex Duct Unit. The red alarm LED on the circuit board will be illuminated and the alarm relay outputs will change state. Using a multimeter set to OHMS (or continuity buzzer function on the meter) place the meter probes on the following terminals and ensure the contacts are closed (continuity) 8, 9-11, 12 when releasing the test/reset button these contacts will open.

The trouble contacts 13, 14, 15 will not change state in the event of a fire alarm, operational or functional testing. The trouble contacts can be tested by rotating the Apollo detector head counter-clockwise and removing the detector head. This action will extinguish the pilot (green) LED and cause the trouble contacts to change state, 13, 14 will be closed (continuity) 14, 15 will be open circuit. Replacing the detector head and rotating it clockwise until it locks, will cause the green pilot LED to be illuminated and the unit will be operational, terminals 13, 14 will be open circuit and 14, 15 will be closed (continuity).

FUNCTIONAL TESTING

Once operational testing is concluded the unit requires functional testing to determine the correct operation of the detector head.

With the clear cover removed and using the aerosol test smoke Apollo test gas part # 29600-105 or Home Safeguard test gas part # RW-25S-TG (Obtainable from Air Products and Controls Inc.) Spray the test gas directly at the detector head from a distance of 12 inches for at least 2 seconds.

CAUTION **SPRAYING FROM A DISTANCE CLOSER THAN 12 INCHES CAN CAUSE DETECTOR CONTAMINATION.**

After 15 to 20 seconds the detector head will go into alarm, illuminating the detector head LED and causing the duct unit functions to operate, relays will change state and the remote accessories if attached will function.

If no test gas is available to conduct the testing, blow smoke from a cotton wick or punk directly at the head to cause alarm. The alarm indicator will illuminate within one minute.

Should testing be required for simulated fire conditions, smoke bombs placed in the duct may not be suited for the particular detector head selected and installed.

S60A Ionization Detector Head 2850 - 250 utilizes a radio active source as its means of detection and will detect smoke particles of between .1 and 1 micron in size.

S60A Photoelectric Detector Head 2850 - 350 operates on the principle of light scatter and will detect smoke particles of between 1 and 10 microns in size.

When purchasing smoke bombs for functional testing, ensure smoke particle sizes comply with the criteria as described above.

MAINTENANCE

Each installation location must be assessed on its own merits. If the protected area is of a very dirty nature then the Firex Duct units will have to be checked and cleaned on a Quarterly basis or when cleaning is required.

As a guideline the detector head should be cleaned every six months or as required.

The best methods of cleaning are to vacuum the detector head thoroughly or to blow the detector head out using compressed air.

Do not use chemicals to clean the detector head housing as this could contaminate the detector head and damage the casing.

Sensing tubes must be inspected and cleaned in accordance with the schedule as determined above, to allow the free flow of air through the sensing tube.

Electrical Installation

WIRING

Prior to connecting power to the Firex 2650-660 and 2650-661 duct units, determine the correct input voltage and ensure it is connected to the correct terminals. (Refer to power connections)

24V AC/DC, Terminals 5, 6; 115V AC, Terminals 1, 2, 3; 230V AC, Terminals 1, 2, 4

POWER CONNECTIONS:

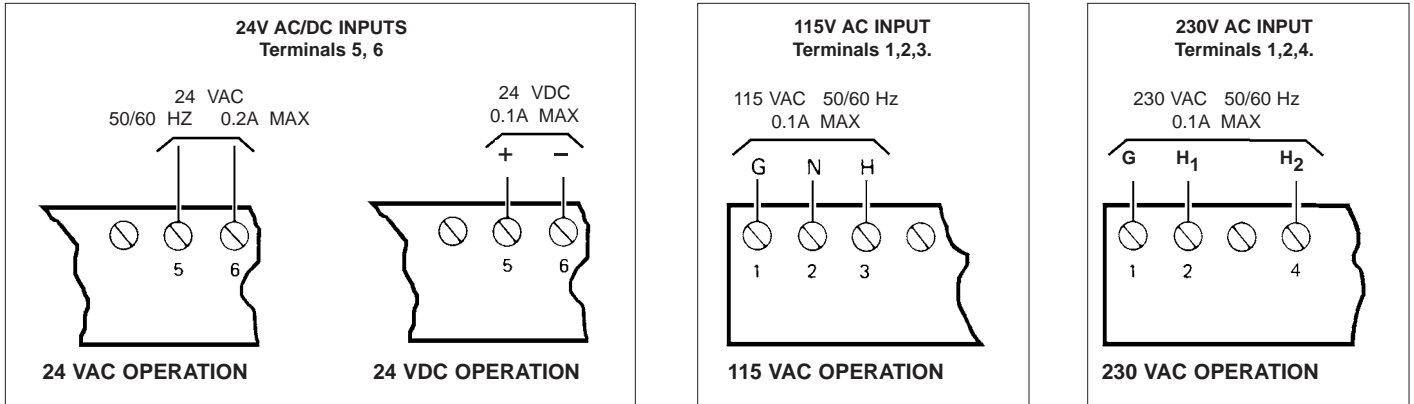

PRODUCT SPECIFICATIONS

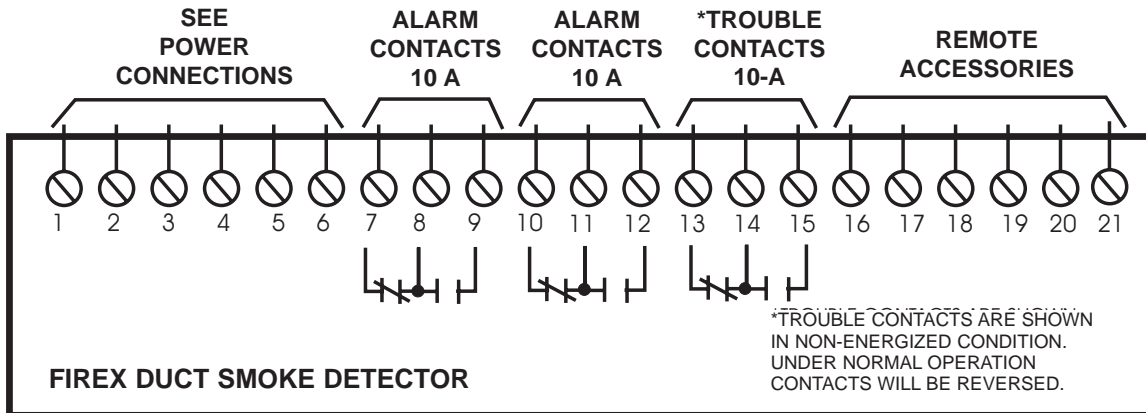

CAUTION:

For terminals 7, 8, 9 - 10, 11, 12 do not use looped wire under terminals. Break wire run to provide supervision of connections. To test the correct operation of the duct smoke unit, excluding the detector head (see functional testing page 4) remove detector head and connect one of the appropriate dedicated power sources to the applicable terminals (See above). Replace detector head and the unit will be energized (The green LED will be illuminated). When pressing the test/reset button the red alarm LED will be illuminated. In the event of a fire alarm, certain equipment may have to be shut down. A shut down will be achieved by interrupting the supply source to that particular piece of equipment when wired as indicated below.

EXAMPLE:

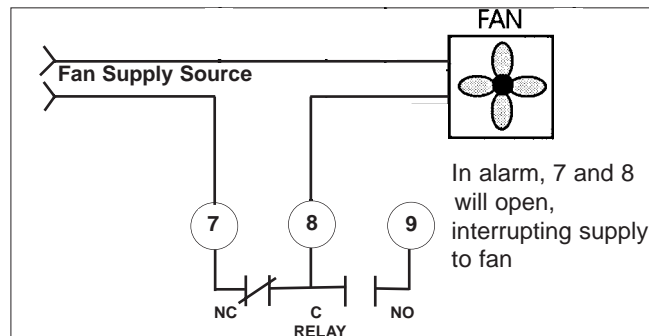

FirexDuct Unit

COMMON FUNCTIONS

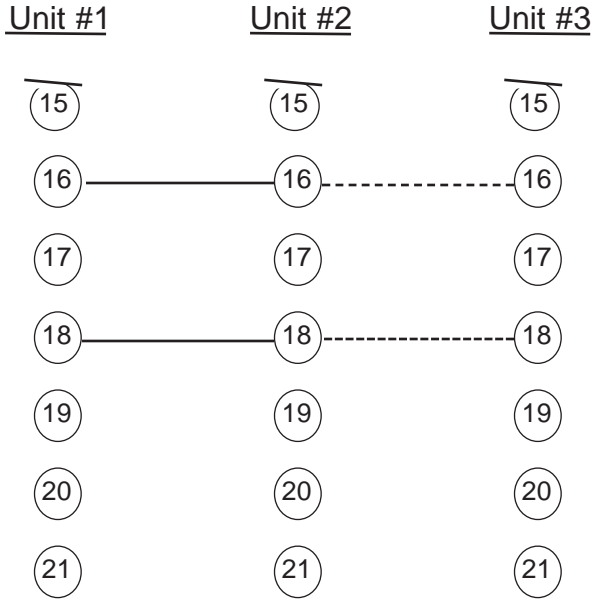

ALL RELAYS OPERATE WITH SINGLE ALARM

30 DETECTORS MAX

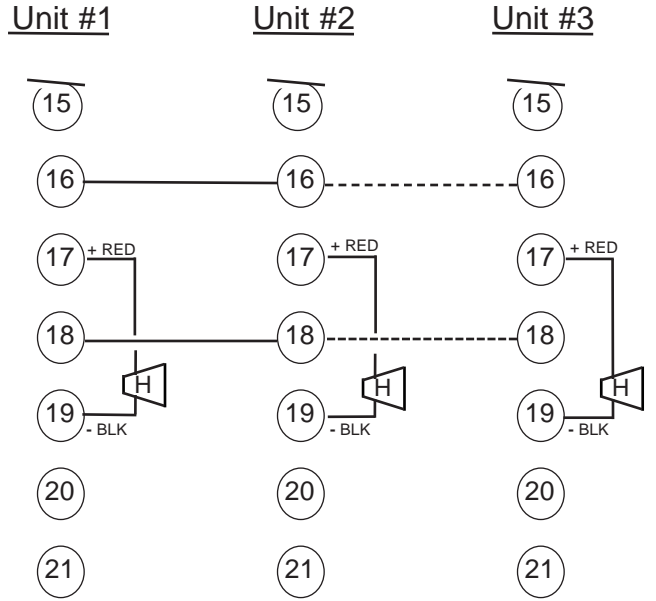

ALL RELAYS OPERATE WITH SINGLE ALARM

INDIVIDUAL HORN/STROBE OPERATE ON ALARMED DETECTOR ONLY

(HORN/STROBE SHOWN IN THIS DIAGRAM)

30 DETECTORS MAX

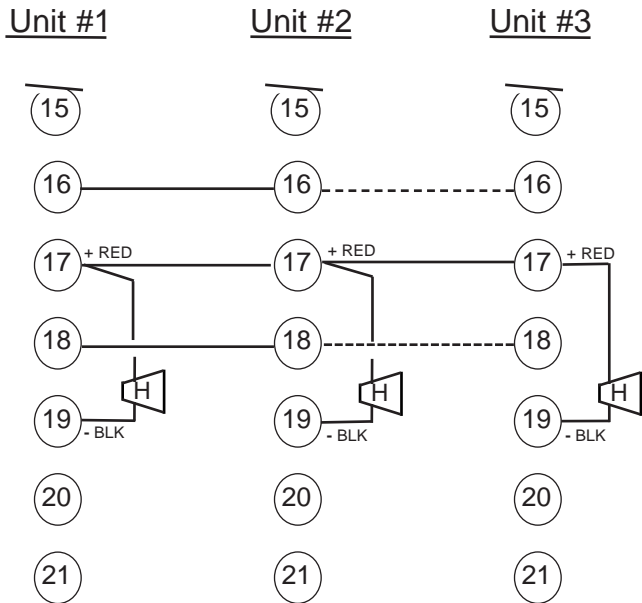

ALL RELAYS OPERATE WITH SINGLE ALARM

ALL HORN/STROBES OPERATE WITH SINGLE ALARM

(HORN/STROBE SHOWN IN THIS DIAGRAM)

15 DETECTORS MAX

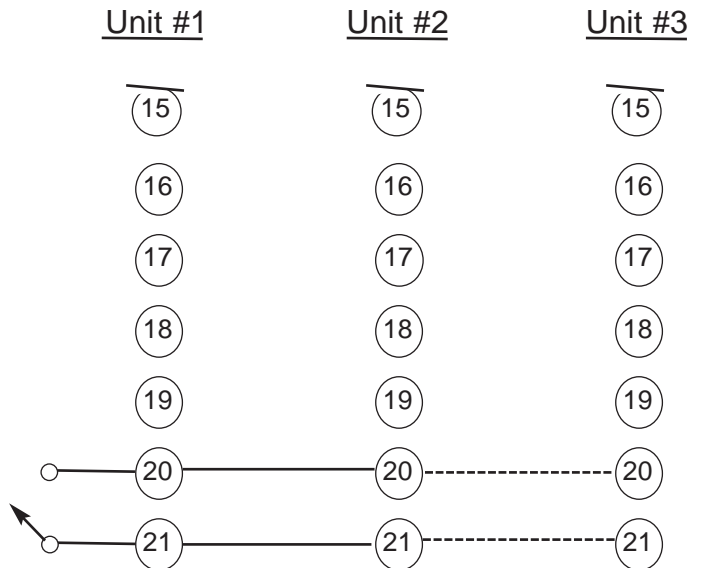

NORMALLY OPEN RESET SWITCH

COMMON TEST/RESET

30 DETECTORS ONLY

REMOTE ACCESSORY WIRING

NOTE: ONLY USE APPROPRIATE ACCESSORIES AS INDICATED BELOW. DO NOT USE ANY OTHER MANUFACTURER'S ACCESSORIES WITH THIS DETECTOR.

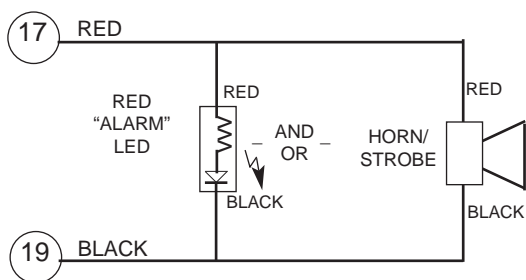

ALARM

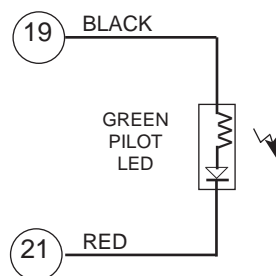

PILOT

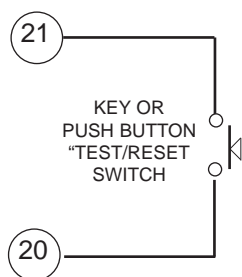

TEST / RESET

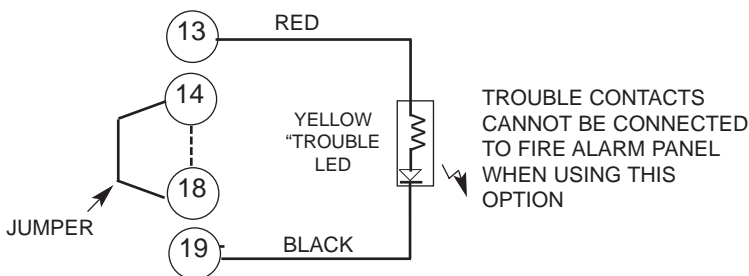

TROUBLE

Fire Alarm Control Panel Wiring

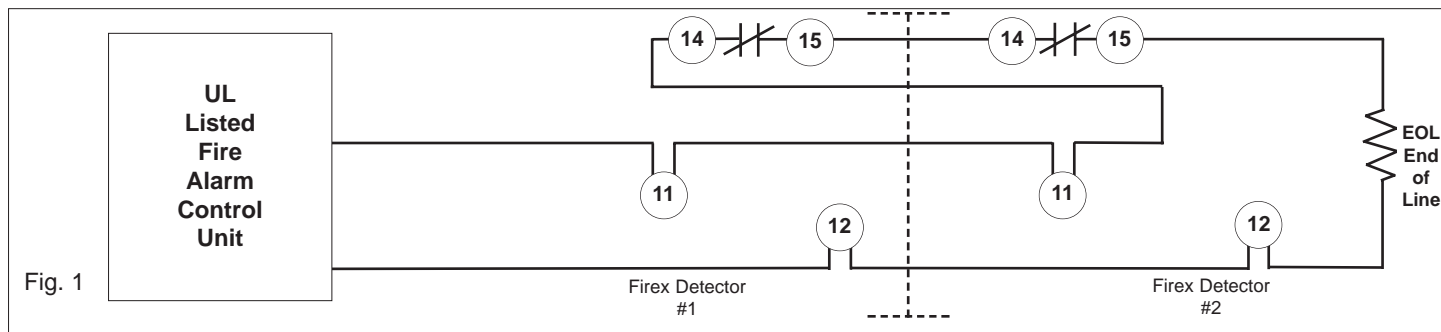

Remote Accessories Approved For Use With This Detector

- | | |
|---|--|
| 535 Remote Alarm | 542 Remote Alarm, Pilot, Horn, key-operated Test/Reset Switch |
| 536 Remote Alarm, push button Test/Reset Switch | 543 Remote Alarm, Pilot, Horn |
| 537 Remote Alarm, Pilot, push-button Test/Reset Switch | 544 Remote Alarm, Trouble, Pilot, Horn, key-operated Test/Reset Switch |
| 538 Remote Alarm, key-operated Test/Switch | 545 Horn/Strobe, red housing, clear cover |
| 539 Remote Alarm, Pilot, key-operated Test/Reset Switch | 546 Horn/Strobe, white housing, opaque cover |
| 540 Remote Alarm, Pilot | 547 Horn/Strobe, white housing, clear cover |
| 541 Remote Alarm Horn | |



Maple Chase Company

2820 Thatcher Road

Downers Grove, Illinois 60515 USA

Telephone +1 630 719 5500 Facsimile +1 630 719 4400

Technical Service Telephone +1 800 445 8299

E-mail mctechservices@maplechase.com

www.maplechase.com