

SMOKE ALARM PHOTOELECTRIC

CAT.
7010/7010B



360
OptiPath 360
Technology

PHOTOELECTRIC

Photoelectric technology is generally more sensitive at detecting large particles, which tend to be produced in greater amounts by smoldering fires. Sources of these fires may include cigarettes burning in couches or bedding.

OPTIPATH 360 TECHNOLOGY™

Exclusive patented inverted smoke sensor.

ALARM INDICATION

Automatically identifies which unit initiated an alarm.

TWO LOCKING FEATURES

Pins are provided to lock battery drawer (7010B only) and/or alarm to base. Great for apartment, dormitory or hotel applications where unauthorized removal of battery or alarm is not desired.

Available in the following versions:

7010 AC only Alarm

7010B AC Alarm with battery backup

Distributed by:



BRK®

120V AC, 60Hz Wire-in (7010) with 9V Battery Back-up (7010B)

Description:

The BRK Electronics® Cat. No. 7010 and 7010B are wire-in, 120 VAC 60Hz single and/or multiple station smoke alarms specifically designed for residential and institutional applications including sleeping rooms of hospitals, hotels, motels, dormitories and other multi-family dwellings as defined in standard NFPA 101. Both models comply with UL217, CSFM, NFPA 72, HUD, FHA and other agencies that model their codes after the above agencies. It meets building codes where AC or AC/DC smoke alarms are required.

BRK Electronics® 7010 and 7010B feature a photoelectric smoke sensing chamber, an 85dB horn, single button test/silence, an easy access side-load battery drawer, a green LED power light and a red LED light that indicates either unit is operating under DC power or is in alarm. The 7010B features a 9V battery backup power supply. OptiPath360 Technology™: Exclusive patented Smoke sensor allows 360° access to the layer of air on the ceiling or wall that carry the fire signatures (smoke, combustion particles and volatile components). Both are interconnectable with up to 18 devices, of which 12 can be smoke alarms. The alarm feature automatically identifies which unit initiated an alarm. The red LED indicators remain off on all other interconnected units. The unit mounts to any standard junction box up to 4" size. Keyhole slots in the mounting bracket eliminate the need to remove the junction box screws for installation. Includes a gasketless base for easy installation and a new mounting bracket that keeps the alarm secure over a wide rotation range to allow for perfect alignment. Dust cover is included to keep the alarm clean during construction. On the 7010B, battery installation and removal can occur while the unit is mounted to the ceiling or wall via the side load battery compartment.

Two locking features are provided to prevent battery theft (7010B only) and/or theft of the unit. Connection to AC power is made with a "Quick-Connect" wiring harness. Installation is quick, easy and cost effective.



CAT. 7010/7010B



120V AC/DC, 60Hz Wire-in
with 9 V Battery Back-up (7010B only)

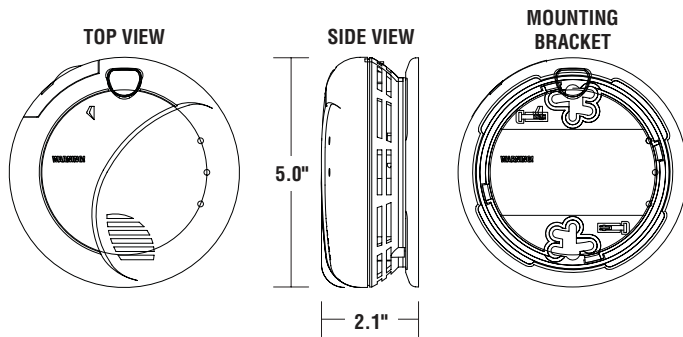

ARCHITECTURAL AND ENGINEERING SPECIFICATION:

1. A photoelectric sensing chamber.
2. The unit shall be capable of self restoring.
3. A fully screened sensing chamber to prevent entry of small insects thereby reducing the probability of unwanted alarms.
4. Powered by 120V AC, 60Hz and have a monitored 9V battery backup (7010B only) and a solid state piezo horn rated at 85dB at 10 ft.
5. A visual LED (green) power-on indicator to confirm unit is receiving power. A visual LED (red) power-on indicator to confirm unit has switched to battery backup mode for 7010B only.
6. A single button test/silence feature. Test button should check all alarm functions by simulating a smoke condition, causing the unit to alarm. The silence feature to temporarily silence unwanted alarms.
7. The unit shall be capable of operating between 40F (4C) and 100F (38C) and relative humidity between 10% and 90%.
8. The unit shall center mount to any standard electrical junction box up to 4" size without screw removal and shall be listed for wall or ceiling mounting.
9. The unit shall have an optional locking mechanism to deter battery (7010B only) and/or theft of the unit.
10. The unit shall have a dust cover to keep alarm clean during construction.
11. Features a quick-connect wiring harness and be capable of interconnecting up to 18 devices, 12 of which can be smoke alarms.
12. The unit shall at a minimum meet the requirements of UL217, CSFM, NFPA 72, NFPA 101, ICBO, BOCA, SBCCI and CABO.

INSTALLATION OF SMOKE ALARM

Installation of this smoke alarm must conform to all local electrical codes and Article 760 of the National Electrical Code (NFPA 70) and NFPA 72. Interconnected units must meet the following requirements: Total length of wire interconnecting units should be less than 1000 feet, be #18 gauge or larger and be rated at least 300V. It is recommended that all units be on the same fuse or circuit breaker. If local codes do not permit, be sure the neutral wire is common to both phases. Only those BRK Electronics® catalog numbers listed in the "Technical Specs" section under "Interconnection" may be connected to these smoke alarms.

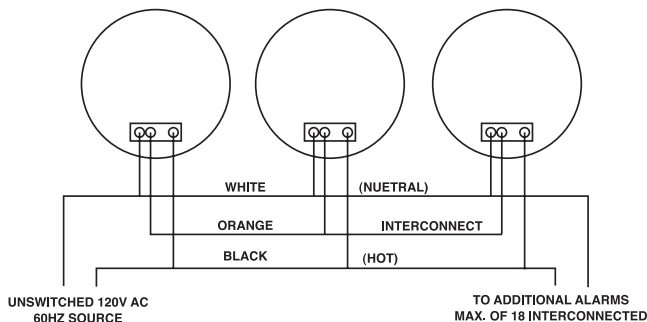

BRK ELECTRONICS®

TECHNICAL SPECS:

Alarm Dimensions	5.0" dia x 2.1"H
Weight	6.7 oz. (7010) 8.4 oz. (7010B)
Operating Voltage	120V AC 9V battery backup (7010B only)
Operating Current	.045 amps (standby/alarm)
Temperature Range	40°F (4°C) to 100°F (38°C)
Humidity Range	10% to 90% relative humidity (RH)
Audio Alarm	85dB at 10 feet
Test Button	Electronically simulates the smoke condition, causing the unit to alarm.
Alarm Reset	Automatic when smoke clears
Interconnections	Up to 18 units with Cat. Nos. 100S, 2002RAC, 4120, 4120AB, 4120B, 4120SAB, 4120SB, 7010, 7010B, 5919, HD6135FB and RM3. Maximum of 12 smoke alarms.
Sensor	Photoelectric
Indicator LEDs	AC Power: Constant Green LED DC Power (7010B only): Intermittent Red LED Local Alarm: Red LED flashes rapidly Remote Alarm: Red LED off
Listing	UL 217

SHIPPING SPECS:

	7010	7010B
Individual Carton Dimensions	5.13"L x 2.38"W x 5.13"H	5.13"L x 2.38"W x 5.13"H
Weight	.45 lbs.	.55 lbs.
Cube	.04 ft ³	.04 ft ³
UPC	0 29054 11200 2	0 29054 11201 9
Master Carton Dimensions	10.75"L x 7.88"W x 11.06"H	10.75"L x 7.88"W x 11.06"H
Master Pack	12	12
Weight	5.875 lbs.	7.075 lbs.
Cube	.54 ft ³	.54 ft ³
UPC	100 29054 11200 9	100 29054 11201 6
Pallet Information		
Cases per Layer	22	22
Number of Layers	4	4
Cases per Pallet	88	88
Cube	54.04 ft ³	54.04 ft ³
Weight	572 lbs.	677.6 lbs.

Manufactured By:
BRK Brands, Inc.
3901 Liberty Street Road
Aurora, IL 60504-8122

BRK ELECTRONICS®
www.brkelectronics.com

BRK ELECTRONICS® is a registered trademark of BRK Brands, Inc.

©2004 BRK Brands, Inc.,
CM2459